



来自西班牙的自动化设备专家

Expert Of Automatic Equipments Manufacture From Spain

质量是生命 诚信得商机

设备报价单
Quotation

宁波意德西专用设备科技有限公司

NINGBO ITC SPECIALIZED EQUIPMENT TECHNOLOGY CO., LTD.

电话 TEL: +86-574-63077646/+86-13777004313

咨询 QQ: 827971807, 微信 wechat: guxingwujiang

Email: tradeningbo@foxmail.com

传真 FAX: +86-574-63077648

网址 WEB: www.yidexi.cn

地址: 浙江省宁波杭州湾新区滨海一路欧洲工业园 A 区

EUROPEAN INDUSTRIAL PARK, FIRST SEASHORE ROAD, HANGZHOU BAY

NEW ZONE, NINGBO CITY, ZHEJIANG PROVINCE

直线装配测试流水线

TWO BELT ASSEMBLY AND TEST LINE FOR FAUCET

一、生产效率 efficiency

双皮带装配测试流水线基本产能表（单边设备）two belt line for faucet assembly and test(one side of machines)

Code 编号	Faucet 水龙头	Capacity per team(pcs) 每组产能	Working hours(H) 工作小时数	Remark 备注
1	Basin 面盆	1000	8	4 operators compose one team 4人每组
2	Shower 淋浴	750	8	
3	Bath crock 浴缸	550	8	
4	Food bowl 菜盆	680	8	
5	Women wash 妇洗	830	8	

Note: the above data of capacity provided by large enterprise in the faucets manufacture field. 该产能数据由水龙头生产领域大型企业提供。

二、设备技术参数 equipment parameter:

使用条件 Using Condition	参数 parameter
供电电压 Power supply voltage	220V 交流 AC
设备功率 Equipment power	150W
压缩空气源 Compressed air supply	≥0.7Mpa
最大压紧力 Max compaction power	600N(750N 可选)
辅助压力 Supplementary pressure	480N
测试气体压力 Pressure for testing air	0.2MPa~0.6Mpa

单通道测试时间 Single channel test time	3-10s
测试精度 Text precision	1mbar
标准测试通道 Standard test channel number	3+3

三. 直线装配测试流水线设备

1. ITC-DXL 倒螺旋螺一体机 faucet assembly machine



Counter-nut assembly:

工作压力 Work pressure	0.3-0.8Mpa
扭力 Torsion	10-60N/m
转速 Revolve speed	550r/min
适用于各种倒螺件的装配 It is suitable for assembly of various kinds of counter-nut	

Cartage assembly

工作压力 Work pressure	0.4-0.7Mpa
扭力 Torsion	5-25N.m
转速 Revolve speed	400r/min
工作高度 Work height	140mm-350mm
工作台面积 Work table area	180mm×160mm

2. ITC-SQC2-3 高精密气密性测试机 air-tightness test machine



型号 model	供电电压 Power supply voltage	设备功率 Equipment power	压缩空气源 Compressed air supply	压紧力 compaction power	测试气体压力 Pressure for testing air	单通道测试时间 Single channel test time	测试精度 Text precision	标准测试通道 Standard test channel number
ITC-SQC2-3	220V 交流 AC	150W	0.8Mpa	600N(750N 可选)	0.4Mpa-0.8Mpa	1-10s	1mbar	(3/5) *2

3. 8 米双皮带流水线 8 meter two belt line



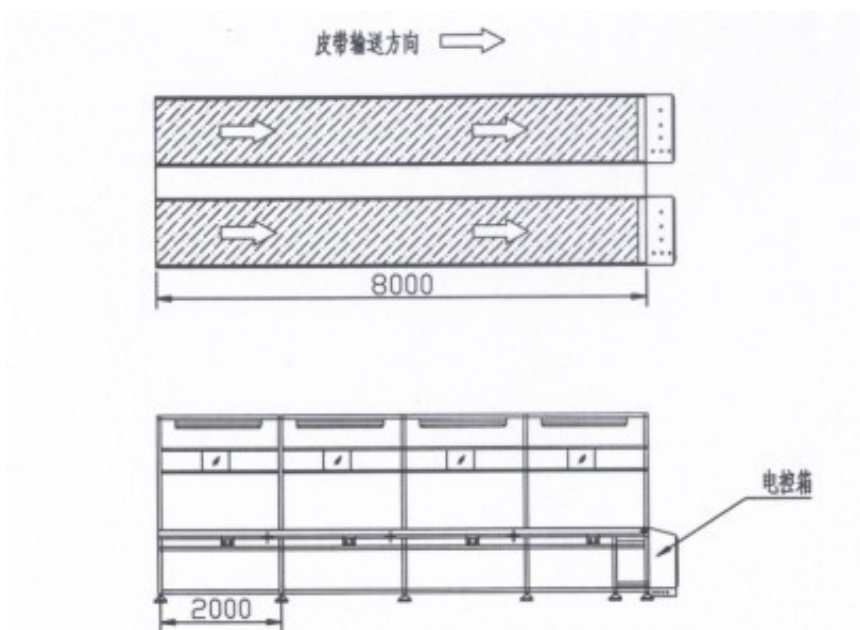
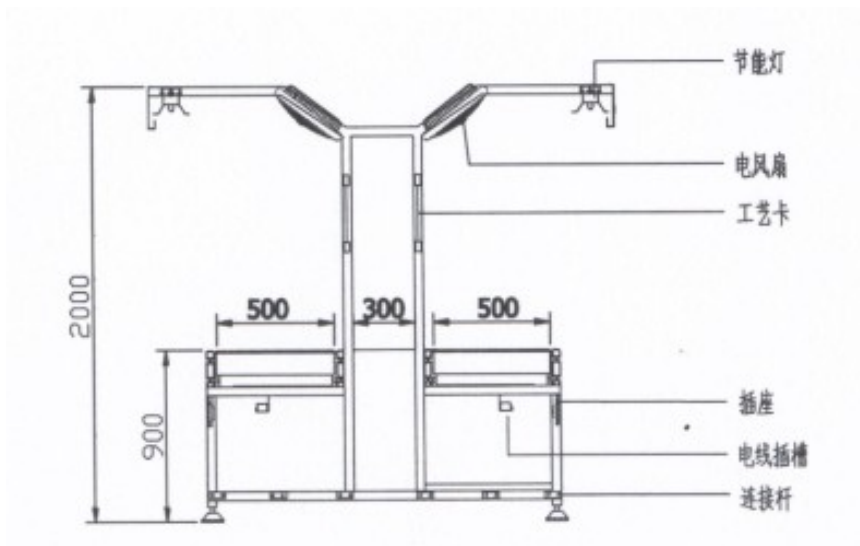

备注：该方案为双皮带线，两组设备共用一条双皮带线。

Remark: this is two belt line, two production line of machines use one two belt line.

五、设备主要配件 EQUIPMENT COMPONENTS

序号 CODE	配件名称 COMPONENTS	产地 COUNTRY
1	压力保压分析数据识别系统 system for pressure analysis	美国 USA
2	压力数据传送识别系统 pressure data transfer and recognize system	意大利 ITALY
3	传送信号屏蔽系统 transfer signal prevent system	德国 GERMANY
5	压力变送器 pressure transfer system	瑞士 SWITZERLAND
6	旋螺枪 motor for cartridge assembly	德国 GERMANY



7	导螺马达 nut assembly motor	德国 GERMANY
8	电磁阀 magnetic valve	日本 JAPAN
9	PLC 西门子 SIMENS	德国 GERMANY
10	旋转手柄马达 handle assembly motor	台湾 TAIWAN
11	西门子触摸屏 SIMENS screen	德国 GERMANY
12	端子（魏德米勒）terminal(WADE MILLER)	德国 GERMANY
13	按钮（施耐德）bottom(Schneider)	法国 FRANCE
14	继电器（欧姆龙）relay(OMRON)	日本 JAPAN

六、设备价格 QUOTATION

EQUIPMENT NAME	MODEL	UNIT	FAVORABLE FOB NINGBO USD	QUANTITY	FAVORABLE FOB NINGBO USD
双工位气密性测试机 DOUBLE WORKING POSITION LEAKAGE TEST MACHINE	ITC-SQC2-3	台 set		1	
倒螺旋螺一体机 FAUCET ASSEMBLY MACHINE	ITC-DXL	台 set		1	
双皮带线 TWO BELT LINE	8 meter	条 set		1	
工作台 WORKING TABLE		个 pcs		3	
FAVORABLE PRICE	USD:20492.00				
REMARK					
DATE OF DELIVERY	30 days after order				
TRANSPORTATION	FOB ningbo				
PAYMENT TERM	30% deposit, 70% before delivery				

Videos:

电话: 13777004313

传 真: 0574-63077648

U-LINE FOR FAUCET ASSEMBLE AND LEAKAGE TEST

https://www.youtube.com/watch?v=qv_s6x0wiJ0

U-LINE FOR FAUCET ASSEMBLE AND LEAKAGE TEST

<https://www.youtube.com/watch?v=Q3S0LPwad5Y>

FAUCET ASSEMBLY AND LEAKAGE TEST LINE

<https://www.youtube.com/watch?v=KGOOGIvojEk>

AUTOMATIC COUNTER-NUT FACILITY

<https://www.youtube.com/watch?v=RynMmHoyXsY>

FAUCET THREE WORKING POSITION LEAKAGE TEST MACHINE

<https://www.youtube.com/watch?v=ZdwtT4ufE0>

FAUCET DOUBLE WORKING POSITION LEAKAGE TEST MACHINE

<https://www.youtube.com/watch?v=ISh7MR1tVvo>

FAUCET DOUBLE WORKING POSITION LEAKAGE TEST MACHINE 2

<https://www.youtube.com/watch?v=KXoOG0jDrp4>

FAUCET DOUBLE WORKING POSITION LEAKAGE TEST MACHINE 3

<https://www.youtube.com/watch?v=29t-V7GDej4>

AUTOMATIC TAP LEAKAGE TEST MACHINE

<https://www.youtube.com/watch?v=RRa1qPD7tnY&feature=youtu.be>

AUTOMATIC POLISH MACHINE FAUCET POLISH

<https://www.youtube.com/watch?v=AZYMKaZ71sY&feature=youtu.be>

AUTOMATIC FAUCET POLISH MACHINE

<https://www.youtube.com/watch?v=uurnJ33NQoc>